



CLEANING & PAINTING INSTRUCTIONS

FIBERGLASS DOORS

CLEANING

Clean the door with a clean, lint-free cloth, removing all dust and foreign debris. For light cleaning, a one part vinegar to ten parts water mixture can be used. For tough dirt removal, use denatured alcohol or mineral spirits making sure all residue is removed by turning the cloth often while cleaning. Allow the door to dry thoroughly.

DO NOT USE SANDPAPER OR LACQUER THINNER AS IT MAY DAMAGE THE FIBERGLASS SURFACE.

PAINTING

Clean the door as outlined in the cleaning section. Wipe dry with a clean cloth before the denatured alcohol or mineral spirits dries. Be sure surface is completely clean and dry before proceeding.

It is recommended that you use high quality exterior grade acrylic latex products to paint your door. Apply paint only when both air and door temperatures are above 50° F. Paint can be spray applied, brushed or roll applied. Spray application is recommended for large surface areas to achieve optimum appearance. Be sure to paint all six sides of the door. If glass is installed in the door, follow painting instructions for the doorlite frame provided on the glasslite. Allow to completely dry before installing any hardware.

STAINING

Clean the door as outlined in the cleaning section. Wipe dry with a clean cloth before the denatured alcohol or mineral spirits dries. Be sure surface is completely clean and dry before proceeding.

Apply an even amount of good quality exterior solvent-based stain, or a gel stain recommended for fiberglass doors. For best results, apply stain with a foam brush or lint free cloth, one section of the door at a time, starting with the embossed panels first and then the flat sections.

Work the stain into the grain using a circular motion. Before stain dries completely, wipe the surface in the direction of the grain with a clean cheesecloth or rag to remove any excess stain. Tip: Use a dry, soft china bristle brush to feather out lap marks and to blend the stain. Remove any excess stain on the brush by wiping on a dry cloth. Then feather the stain until desired color is reached.

If a darker appearance is desired, apply a second coat after the first coat dries. Follow the stain manufacturer's instructions to apply and wipe the stain with a brush or rag. Repeat the staining process on the remaining unstained sides of the door after one side is stained and has completely dried.

Allow stain to dry per manufacturer's recommendations (may take up to 48 hours).

Spray on at least one coat of clear exterior grade polyurethane with UV inhibitors.

THE FIRST COAT MUST BE SPRAYED ON. Additional coats may be sprayed or brushed on.

Repeat process on the remaining unfinished sides of the door. Allow to completely dry before installing any hardware.

DENTIL SHELF INSTALLATION

FIBERGLASS AND HD STEEL CRAFTSMAN DOORS

DENTIL SHELF INSTALLATION

- STEP 1.** Lay the door on a clean flat surface with the exterior of the door facing up.
Clean the door to remove all dirt and debris using a mild soap and water solution. Thoroughly rinse the door with clean water to remove any soap residue. Door must be completely dry prior to dentil shelf installation.
- STEP 2.** Before applying the adhesive tape, place the dentil shelf at the desired location on the door panel. The shelf should be centered on the width of the door and parallel to the glass opening. The shelf should also be centered between the glass opening (flush glazed doors), or door lite frame and the vertical embossments on the panel. Once located lightly mark the position on the door with a graphite pencil along the top and sides of the shelf. **See Fig. 1.**
- STEP 3.** Lightly sand ONLY the backside of the dentil shelf where the adhesive strip will be applied. Ensure the surface is dry and free of all dust, dirt and debris. Without removing the adhesive liner place the adhesive strip against the shelf to determine correct fit. Any protruding portions of the adhesive strip should be trimmed prior to installation.
- STEP 4.** Remove the protective liner on one side only of the adhesive strip and carefully align the adhesive strip with the dentil shelf. Ensure good contact of the adhesive strip and the dentil shelf by applying pressure.
- STEP 5.** Remove the other side of the protective liner and using the pencil marks, locate the shelf on the door panel. Apply firm pressure to the dentil shelf to ensure proper adhesion.
See Fig. 2.

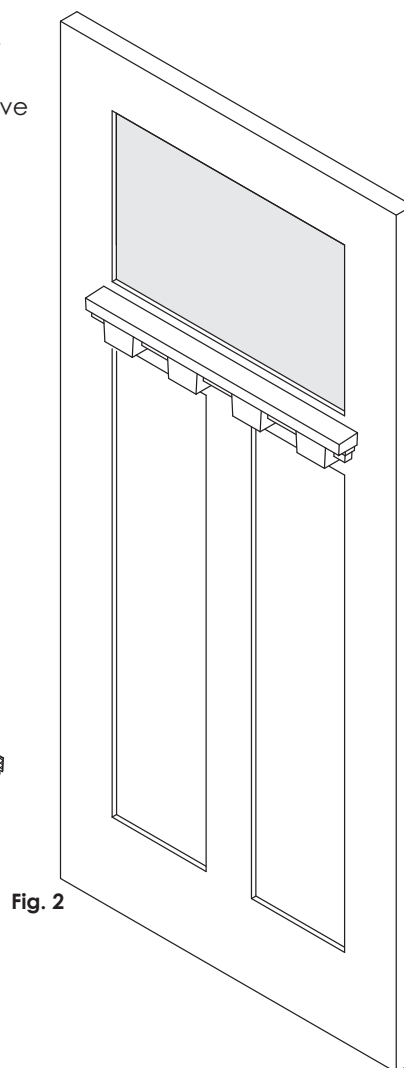
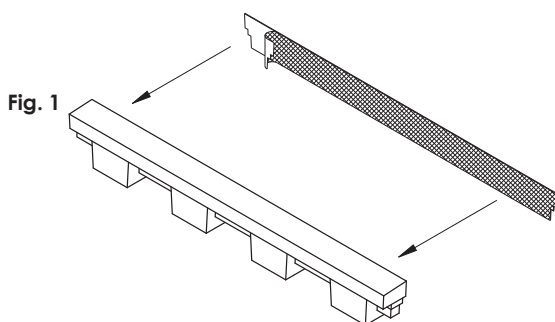

WARRANTIES

HARBOUR CRAFT® ESTATE FIBERGLASS DOORS



HARBOUR CRAFT ESTATE FIBERGLASS DOOR WARRANTY

Subject to the limitations and conditions established below, ODL® Doors warrants that from the date of the original installation, its door panel, when used in residential application will be free of manufacturing defects in the material and workmanship for a period of:

SMOOTH HARBOUR CRAFT FIBERGLASS DOORS 25 YEARS RIFT CUT & MAHOGANY HARBOUR CRAFT FIBERGLASS DOORS LIMITED LIFETIME

ODL grants these warranties only to the original purchaser of the door and the original purchaser of the building where the door was installed.

THIS WARRANTY IS NOT TRANSFERABLE.

This warranty excludes any defects in applied coatings, any glass inserts (where a glass insert is factory installed please refer to the appropriate glass warranty) or other accessories. Also excluded from this warranty are defects resulting from:

- (a) minor scratches or minor visual imperfections
- (b) exposure to air pollutants
- (c) exposure to chemicals, acid or fumes
- (d) improper handling, storage, abuse, vandalism, misuse, impact by a foreign object, natural disasters, fire, explosions or other casualties
- (e) installation or maintenance not conducted in strict adherence to the manufacturer's written instructions (including failure to maintain the finish, see note below)
- (f) air and water infiltration during severe weather conditions
- (g) any failure of the structure/building/foundation into which the door was installed
- (h) damage caused by exposure to excessive heat (e.g. installed behind a non-ventilated storm door that is exposed to the sun)
- (i) modification and/or the installation of hardware, locks, door lites or any other component must not cause any infiltration of water
- (j) damage caused by freight carriers, common carriers, private transportation or any other means of transportation or handling occurring after shipping from ODL
- (k) any other cause beyond the manufacturer's control and not related to the actual manufacturing process.

NOTE: All ODL Harbour Craft fiberglass doors must be finished within six (6) months of the installation date for continued warranty coverage. All doors must have all six (6) sides finished and on out swing doors, the sides, top and bottom must be inspected and maintained as regularly as all other surfaces.

THIS WARRANTY IS IN LIEU OF ANY OTHER WARRANTY, EXPRESSED OR IMPLIED, INCLUDING IMPLIED WARRANTIES OF FITNESS FOR A PARTICULAR PURPOSE AND MERCHANTABILITY. MOREOVER, IN NO EVENT WILL ODL BE LIABLE OR RESPONSIBLE FOR SPECIAL, INCIDENTAL OR CONSEQUENTIAL DAMAGES.

This warranty gives you specific legal rights. Other rights vary from province/state to province/state and may apply to you. Some provinces/states and federal laws do not allow the exclusion of implied warranties. In the event these laws apply, then the length of any implied warranty shall be one (1) year of the shortest time, in excess of one year permitted under applicable law. Similarly, some provinces or states do not allow the exclusion or limitation of consequential damages and if applicable, this limitation will not apply.

If a defect occurs, ODL, at its sole discretion, will furnish a replacement door, repair the door or refund the original purchase price. If ODL chooses to provide a replacement, the Limited Warranty of the replacement will extend only for the balance of the original warranty period. **MAXIMUM LIABILITY IS LIMITED TO THE AMOUNT OF THE ORIGINAL PURCHASE PRICE.**

ODL will not pay for the costs of labor, installation or finishing for any replacement door. No representative of ODL or any other person has any authority whatsoever to assume for ODL any other liability or responsibility in connection with the door warranted herein.

If you have a warranty claim, please notify ODL within 30 days of discovering the defect. Include in the claim, a description of the door, the name and address of owner and installer, proof of purchase and a detailed explanation of the defect.